



**SM-B80HI -manual bowl lift-
Parts Catalogue & Electrical Diagram**

SMAKY AB

Regulatorvägen 21, S-141 49 Huddinge, Sweden

Tel+ 46 8 657 9490

Fax+ 46 8 657 8980

<http://www.smakymixers.com>

e-mail: info@smaky.com

Base Unit-A

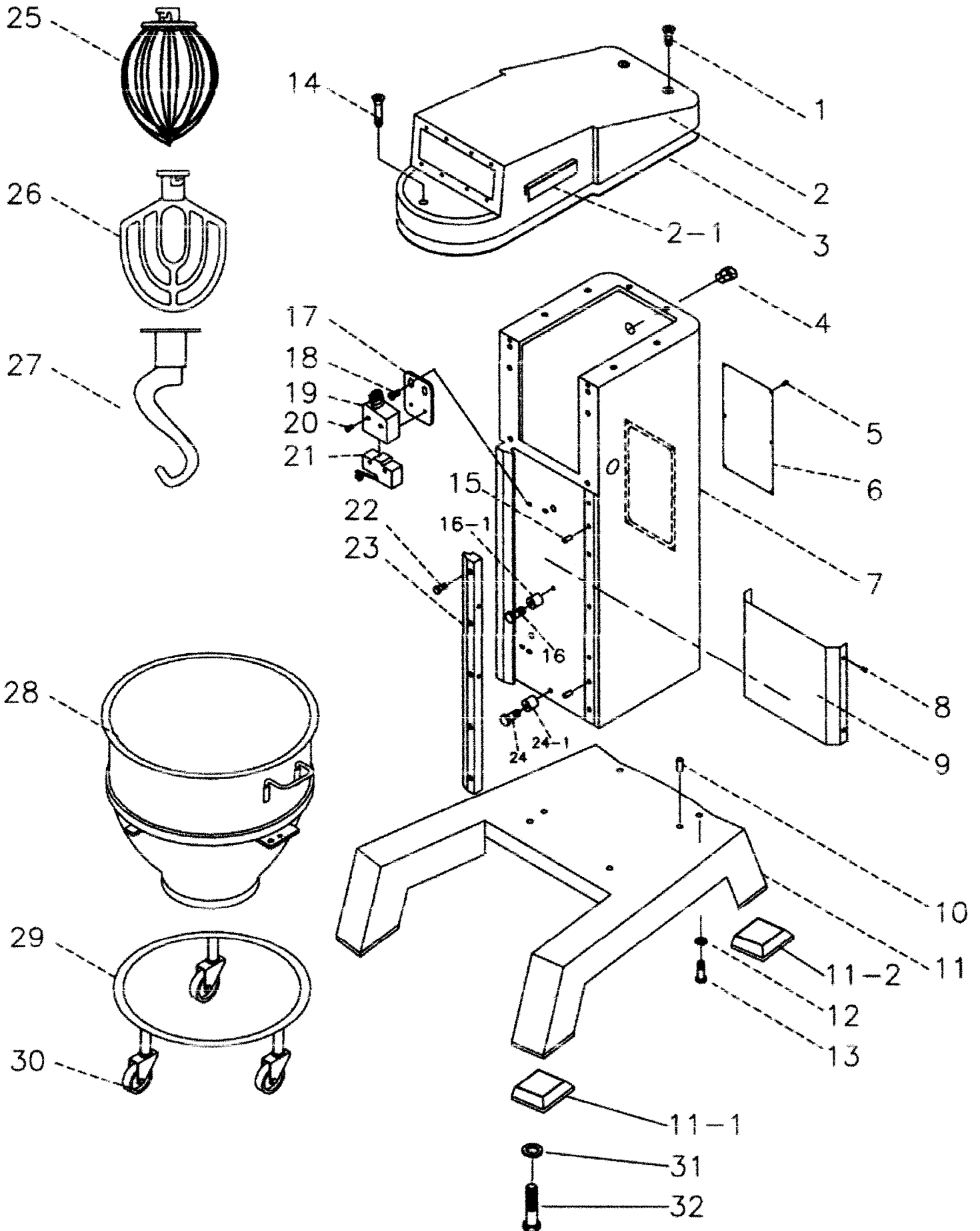

Parts Table A for Base Unit

Item	Parts No.	Name of Parts	Qty.
1	A-8001	Screw: M8x1.25	2
2	A-8002	Transmission case cover	1
2_1	A-8002-1	Strain Reliever	1
3	A-8003	Rubber cover seat	1
4	A-8004	Strain relief	1
5	A-8005	Screw: M5x0.8	6
6	A-8006	Column rear plate	1
7	A-8007	Mixer column	1
8	A-8008	Screw: M5x0.8	4
9	A-8009	Column front plate	1
10	A-8010	Ø 10 mounting pin	2
11	A-8011	base	1
11_1	A-8011-1	Rubber mates (front)	2
11_2	A-8011-2	Rubber mates (back)	2
12	A-8012	Spring washer: M14	4
13	A-8013	Screw: M14x2.0	4
14	A-8014	Screw: M8x1.25	1
15	A-8015	Pin: Ø 10	3
16	A-8016	Screw: M12x1.75	1
16_1	A-8016-1	Sleeve	1
17	A-8017	Mounting plate	1
18	A-8018	Screw: M5x0.8	2
19	A-8019	Micro switch housing	1
20	A-8020	Screw: M4x0.7	2
21	A-8021	Micro switch	1
22	A-8022	Screw: M12x1.75	10
23	A-8023	Front bowl slide	1
24	A-8024	Pin: M12x1.75	1
24_1	A-8024-1	Sleeve	1
25	A-8025	Wire whip	1
26	A-8026	Flat beater	1
27	A-8027	Dough hook	1
28	A-8028	bowl	1
29	A-8029	trolley	1
30	A-8030	(1/2 UNC) wheels	4
31	A-8031	(1/2 UNC) washer	4
32	A-8032	(1/2 UNC) screw	4

Head Unit- B

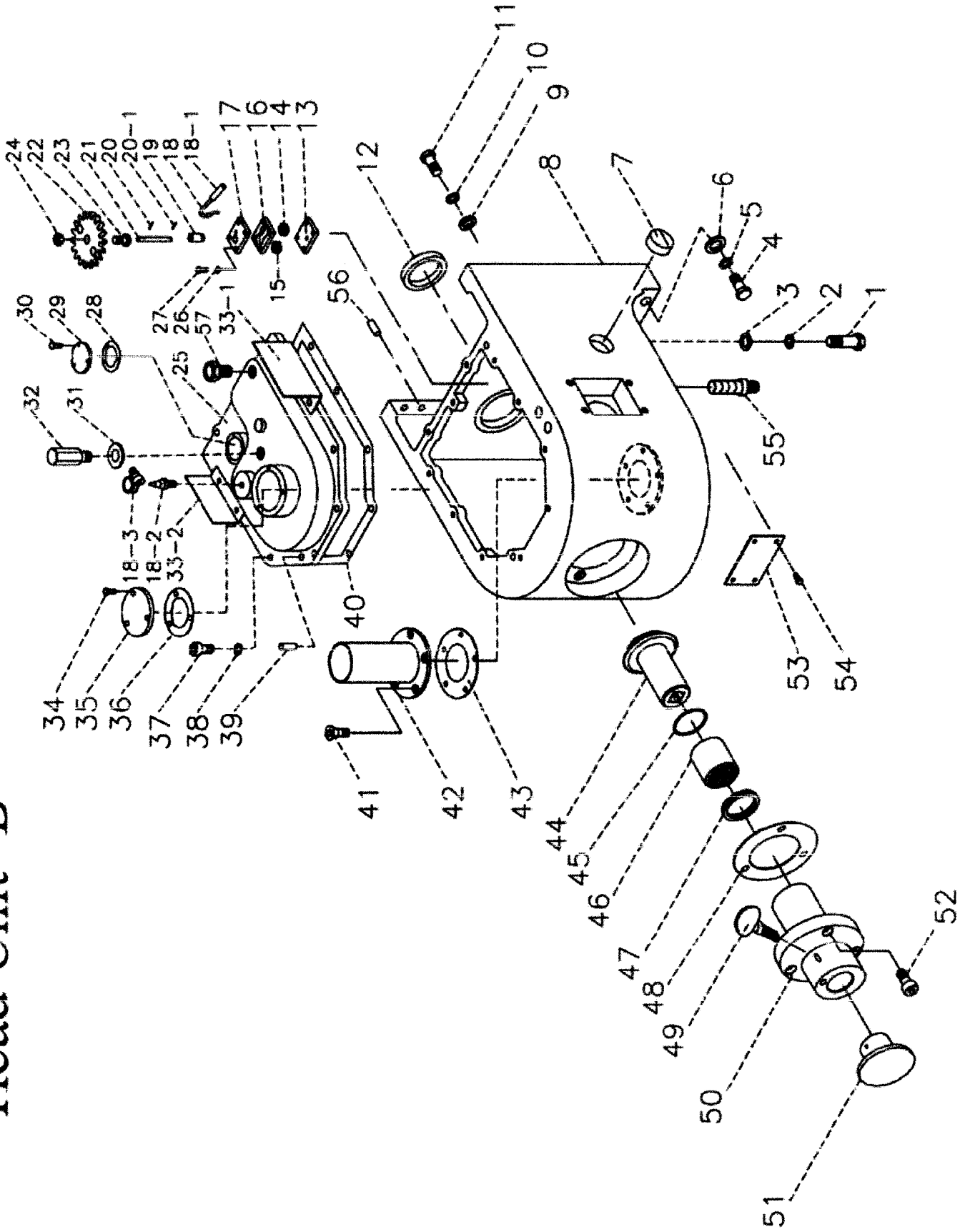

Parts Table B for Head Unit

Item	Parts No.	Name of Parts	Qty.
1	B-8001	Screw: M10x1.5	1
2	B-8002	Spring washer: M10	1
3	B-8003	Washer: M10	1
4	B-8004	Mach screw: M12x1.75	2
5	B-8005	Spring washer: M12	2
6	B-8006	Washer: M12	2
7	B-8007	Gauge oil level	1
8	B-8008	Case transmission	1
9	B-8009	Washer: M12x1.75	6
10	B-8010	Spring washer: M12	6
11	B-8011	Mach screw: M12	6
12	B-8012	Seal oil: TC50x80x10	1
13	B-8013	Plate oil pump bottom	1
14	B-8014	Gear oil pump right: 15T	1
15	B-8015	Gear oil pump left: 15T	1
16	B-8016	Gear set pump	1
17	B-8017	Housing & tube assy	1
18	B-8018	Pup outlet bronze pipe	1
18_1	B-8018-1	Plastic tube	1
18_2	B-8018-2	Fixed screw	1
18_3	B-8018-3	Plastic sleeve	2
19	B-8019	Pump shaft bushing	1
20	B-8020	Rollpin: Ø2x18	1
20_1	B-8020-1	Rollpin:Ø2x10	1
21	B-8021	Shaft oil pump	1
22	B-8022	Gear: 29T	1
23	B-8023	Screw	1
24	B-8024	Nut	1
25	B-8025	Cover transmission case	1
26	B-8026	Spring washer: M5	1
27	B-8027	Screw: M5x0.8	2
28	B-8028	Lead-in oil pad	1
29	B-8029	Transmission shaft Bearing retainer	1
30	B-8030	Screw: 5x0.8	3
31	B-8031	Spring washer: M20	1
32	B-8032	Bolt: M20x2.0	1
33_1	B-8033-1	Top cover assy (right)	1
33_2	B-8033-2	Top cover assy (left)	1

Parts Table B for Head Unit

Item	Parts No.	Name of Parts	Qty.
34	B-8034	Screw: M5x0.8	3
35	B-8035	Retainer-drive shaft bearing	1
36	B-8036	Lead-in oil pad	1
37	B-8037	Cap screw M8x1.25	11
38	B-8038	Washer: M8	11
39	B-8039	Pin: Ø8	2
40	B-8040	Lead-in oil pad gasket	1
41	B-8041	Mach screw: M5x0.8	5
42	B-8042	Lead-in oil bushing	1
43	B-8043	Lead-in oil bush pad	1
44	B-8044	Level drive gear: 16T	1
45	B-8045	Washer-thrust: Ø45	1
46	B-8046	Sleeve square drive TA-35x30	2
47	B-8047	Seal-oil: TC 35x45x8	1
48	B-8048	Lead-in oil pad	1
49	B-8049	(1/2 UNC) thumb screw	1
50	B-8050	Hub-attachment	1
51	B-8051	Plug-attachment hole	1
52	B-8052	Mach screw: M6x1.0	3
53	B-8053	transmission front guard	1
54	B-8054	Screw: M5x0.8	4
55	B-8055	Dowel	1
56	B-8056	Mach dowel: Ø10	2
57	B-8057	Oil tube fixture	1

Lift Unit- C

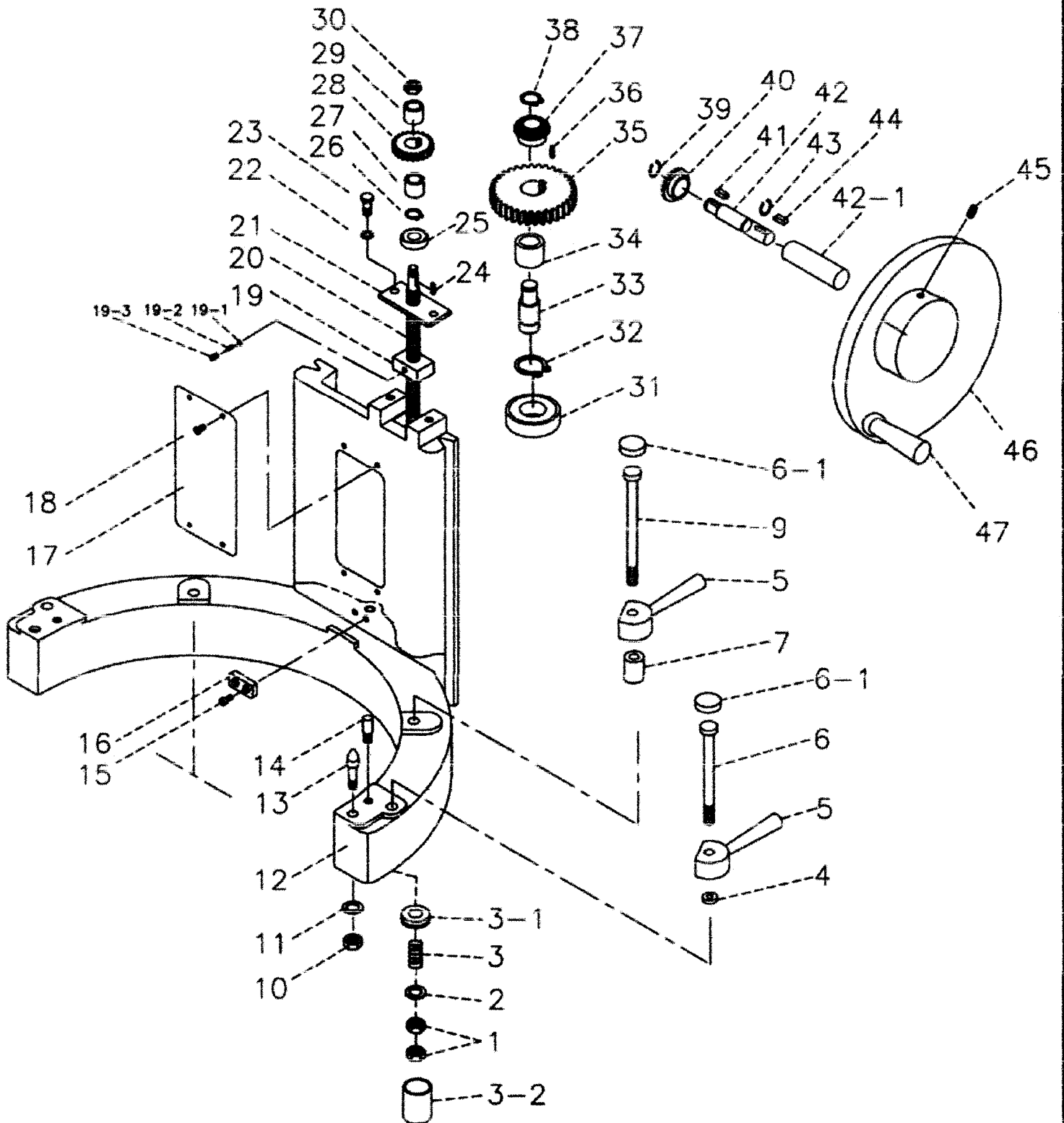

Parts Table C for Lift Unit

Item	Parts No.	Name of Parts	Qty.
1	C-8001	Nut: M12 x 1.75	8
2	C-8002	Spring washer: M12	4
3	C-8003	Spring	4
3 1	C-8003-1	Spacer	4
3 2	C-8003-2	Sleeve	4
4	C-8004	Bronze bushing (front)	2
5	C-8005	Bowl clamps	4
6	C-8006	Screw (front): M12	2
6 1	C-8006-1	Screw cover	4
7	C-8007	Bronze bushing (rear)	2
8	***	***	***
9	C-8009	Screw (rear): M12	2
10	C-8010	Nut: M12	2
11	C-8011	Spring washer: M10	2
12	C-8012	Bowl raise cradle	2
13	C-8013	Screw: M10	2
14	C-8014	Screw: M8	2
15	C-8015	Screw: M8 x 1.25	2
16	C-8016	Locking bracket	1
17	C-8017	Bowl cradle front cover	1
18	C-8018	Screw: M5 x 0.8	4
19	C-8019	Nut	1
19 1	C-8019-1	Ring	1
19 2	C-8019-2	Spring	1
19 3	C-8019-3	Screw: M6 x 1.0	1
20	C-8020	Bowl raise screw	1
21	C-8021	Nut mounting plate	1
22	C-8022	Spring washer: M10	2
23	C-8023	Screw: M10 x 1.5	2
24	C-8024	Key-way: 6 x 6	1
25	C-8025	Ball bearing: 6203	1
26	C-8026	C-ring: RTW-40	1
27	C-8027	Bronze bushing (rear)	1
28	C-8028	Oblique gear: 31T	1
29	C-8029	Bronze bushing (top)	1
30	C-8030	Nut: M16 x 2.0	1
31	C-8031	Ball bearing: 6005	1
32	C-8032	C-ring: RTW-25	1

Parts Table C for Lift Unit

Item	Parts No.	Name of Parts	Qty.
33	C-8033	Drive shaft	1
34	C-8034	Oblique shaft sleeve	1
35	C-8035	Oblique gear: 41T	1
36	C-8036	Pin: 3 x 3	1
37	C-8037	Gear (male): 23T	1
38	C-8038	C-ring: STW:-19	1
39	C-8039	C-ring: STW:-16	1
40	C-8040	Gear (female): 23T	1
41	C-8041	Key-way: 5 x 5	1
42	C-8042	Hand wheel shaft	1
42 1	C-8042-1	Braze sleeve	1
43	C-8043	C-ring: STW-19	1
44	C-8044	Key-way: 5 x 5	1
45	C-8045	Screw: M8 x 1.25	4
46	C-8046	Hand wheel	1
47	C-8047	Handle: M10 x 1.5	1

Gear Box Unit- D

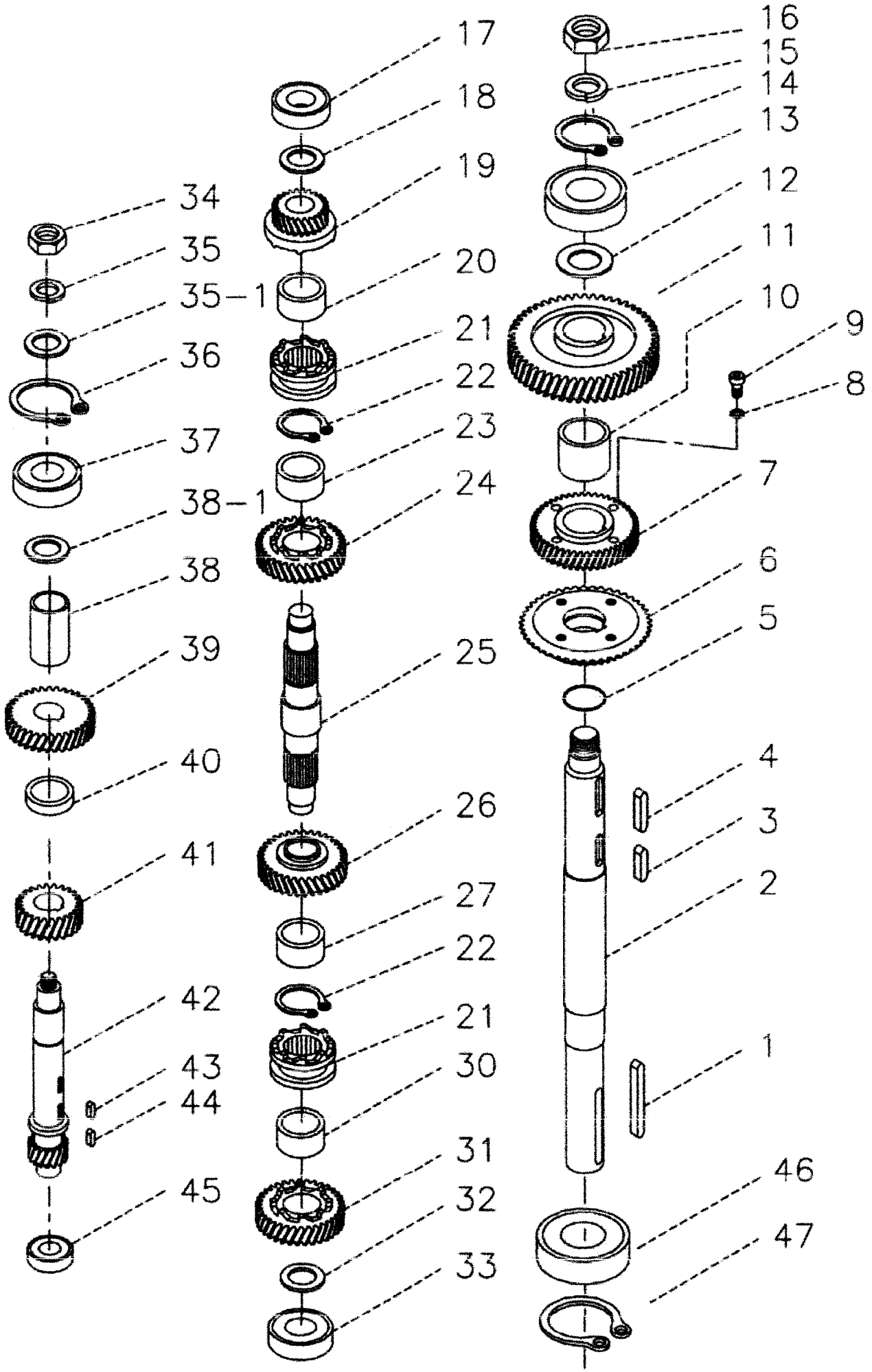

Parts Table D for Gear Box Unit

Item	Parts No.	Name of Parts	Qty.
1	D-8001	Key-way: 10 x 10	1
2	D-8002	Drive shaft	1
3	D-8003	Key-way: 10 x 10	1
4	D-8004	Key-way: 10 x 10	1
5	D-8005	O-ring	1
6	D-8006	Gear: 41T	1
7	D-8007	Main shaft gear: 3T	1
8	D-8008	Spring washer: M8	4
9	D-8009	Screw: M8 x 1.25	4
10	D-8010	Drive shaft bronze bushing	1
11	D-8011	Drive shaft gear: 53T	1
12	D-8012	Drive shaft pad	1
13	D-8013	Ball bearing: 6207LLU	1
14	D-8014	C-ring: RTW-72	1
15	D-8015	Spring washer: M32	1
16	D-8016	Nut: M32 x 1.5	1
17	D-8017	Ball bearing: 6205z	1
18	D-8018	Master shaft pad	1
19	D-8019	Master shaft ear: 17T	1
20	D-8020	Bronze bushing	1
21	D-8021	Clutch sleeve	1
22	D-8022	C-ring: STW-35	1
23	D-8023	Bronze bushing	1
24	D-8024	Master shaft gear: 33T	1
25	D-8025	Master shaft	1
26	D-8026	Master shaft gear: 41T	1
27	D-8027	Bronze bushing	1
28	D-8028	C-ring: S-35	1
29	D-8029	Clutch sleeve	1
30	D-8030	Bronze bushing	1
31	D-8031	Master shaft gear: 49T	1
32	D-8032	C-ring	1
33	D-8033	Ball bearing : 6205z	1
34	D-8034	Nut: M16 x 1.5	1
35	D-8035	Spring washer: M16	1
35_1	D-8035-1	Washer: M16	1
36	D-8036	C-ring: RTW-47	1
37	D-8037	Ball bearing: 6005LLU	2

Parts Table D for Gear Box Unit

Item	Parts No.	Name of Parts	Qty.
38	D-8038	Bronze bushing (top)	1
38_1	D-8038-1	Bronze bushing (down)	1
39	D-8039	Worm gear (50HZ): 29T	1
39_1	D-8039-1	Worm gear (60HZ): 29T	1
40	D-8040	Bronze bushing	1
41	D-8041	Transmission gear: 25T	1
42	D-8042	Transmission gear: 25T	1
43	D-8043	Key-way: 6 x 6	1
44	D-8044	Key-way: 8 x 8	2
45	D-8045	Ball bearing: 6005	2
46	D-8046	Ball bearing: 6009	2
47	D-8047	C-ring: RTW-75	1

Speed Shift Unit- E

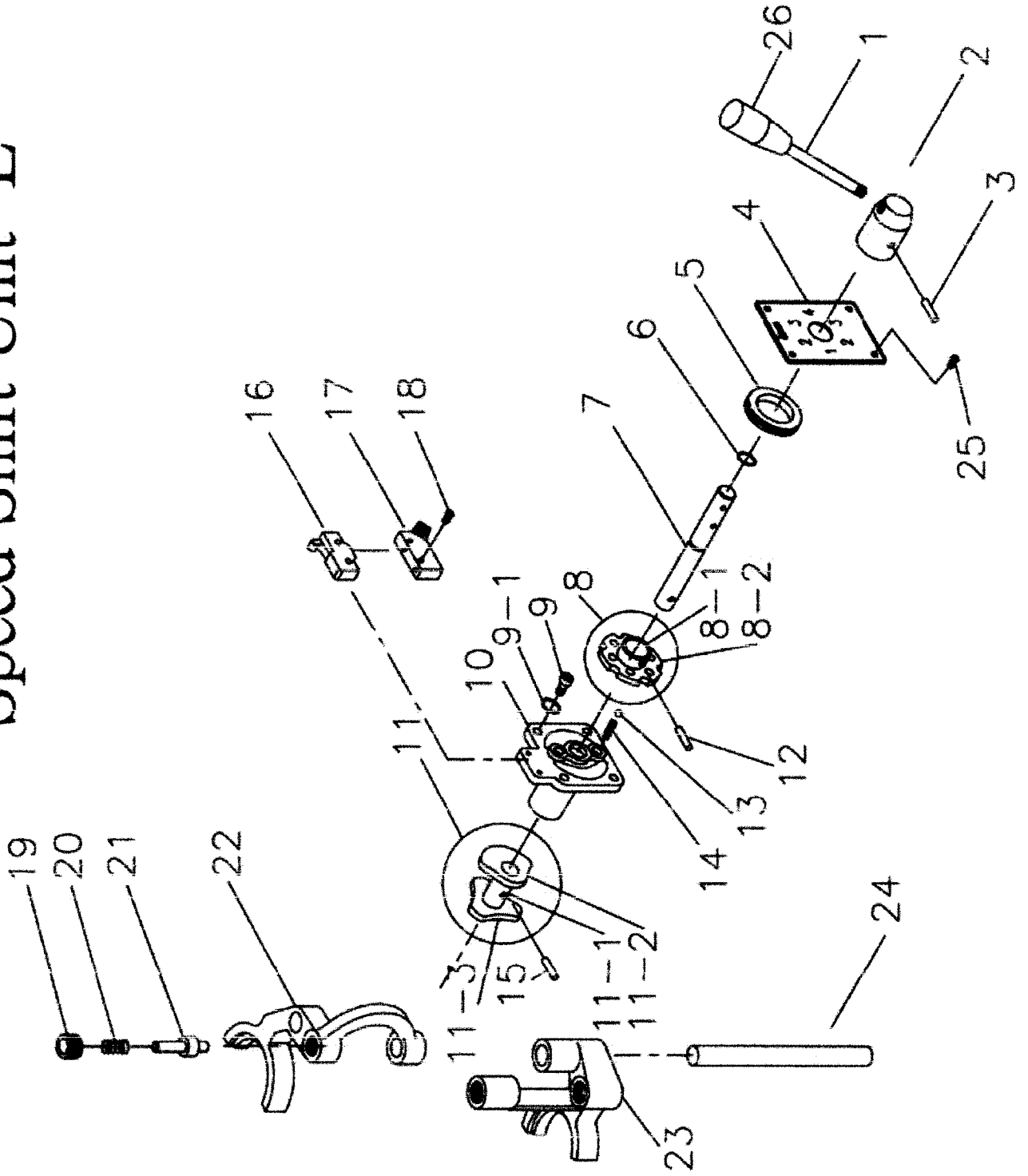

Parts Table E for Speed Shift Unit

Item	Parts No.	Name of Parts	Qty.
1	E-8001	Gear shift arm	1
2	E-8002	Gear shift arm hub	1
3	E-8003	Pin: 6x38	1
4	E-8004	1-4 speed indication plate	1
5	E-8005	Oil seal	1
6	E-8006	O-ring	1
7	E-8007	Shifter guide rod	1
8	E-8008	Hub and cam assembly	1
8_1	E-8008-1	Sleeve	1
8_2	E-8008-2	Plate	1
9	E-8009	Screw: M8x1.25	4
9_1	E-8009-1	Spring washer: M8	4
10	E-8010	Shaft cover	1
11	E-8011	Gear shift cam assembly	1
11_1	E-8011-1	Sleeve	1
11_2	E-8011-2	Plate (front)	1
11_3	E-8011-3	Plate (back)	1
12	E-8012	Pin: M5	1
13	E-8013	Steel ball: M9	2
14	E-8014	Spring : M8	2
15	E-8015	Pin: M6	1
16	E-8016	Micro switch	1
17	E-8017	Micro switch cover	1
18	E-8018	Screw: M4x0.7	2
19	E-8019	Nut: M20x2.0	4
20	E-8020	Spring: M9	4
21	E-8021	Touch shaft	4
22	E-8022	Speed shifter yoke (top)	1
23	E-8023	Speed shifter yoke (rear)	1
24	E-8024	Shifter guide rod	1
25	E-8025	Screw: M5x0.8	4
26	E-8026	Hand knob	1

Planetary Unit- F

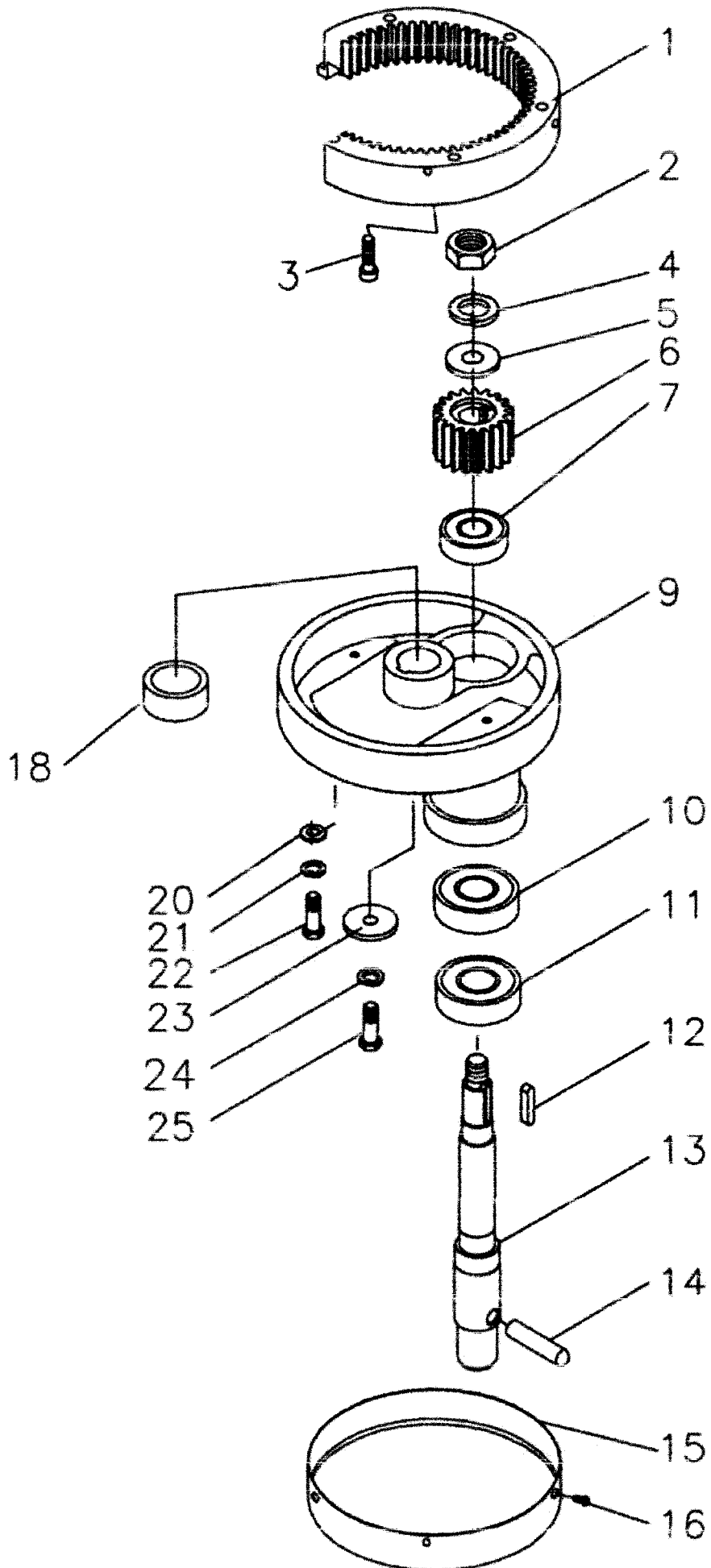

Parts Table F for Planetary Unit

Item	Parts No.	Name of Parts	Qty.
1	F-8001	Planetary gear: 59T	1
2	F-8002	Nut: M16x1.5	1
3	F-8003	Steel screw: M8x1.25	6
4	F-8004	Spring washer: M16	1
5	F-8005	Washer: M16	1
6	F-8006	Pinion gear: 18T	1
7	F-8007	Ball bearing: 6306zz	1
8	***	***	***
9	F-8009	Planetary holder	1
10	F-8010	Ball bearing: 6008	1
11	F-8011	Ball bearing: 6008	1
12	F-8012	Key-way: 6x6	1
13	F-8013	Planetary shaft	1
14	F-8014	Planetary shaft pin: M14	1
15	F-8015	Holder cover	1
16	F-8016	S/S screw: M5x0.8	6
17	***	***	***
18	F-8018	Guard oil busk	1
19	***	***	***
20	F-8020	Washer: M10	2
21	F-8021	Spring washer: M10	2
22	F-8022	S/s screw: M10x1.5	2
23	F-8023	Washer: M10	1
24	F-8024	Spring washer: M10	1
25	F-8025	S/S screw: M10x1.5	1

Motor Unit-G

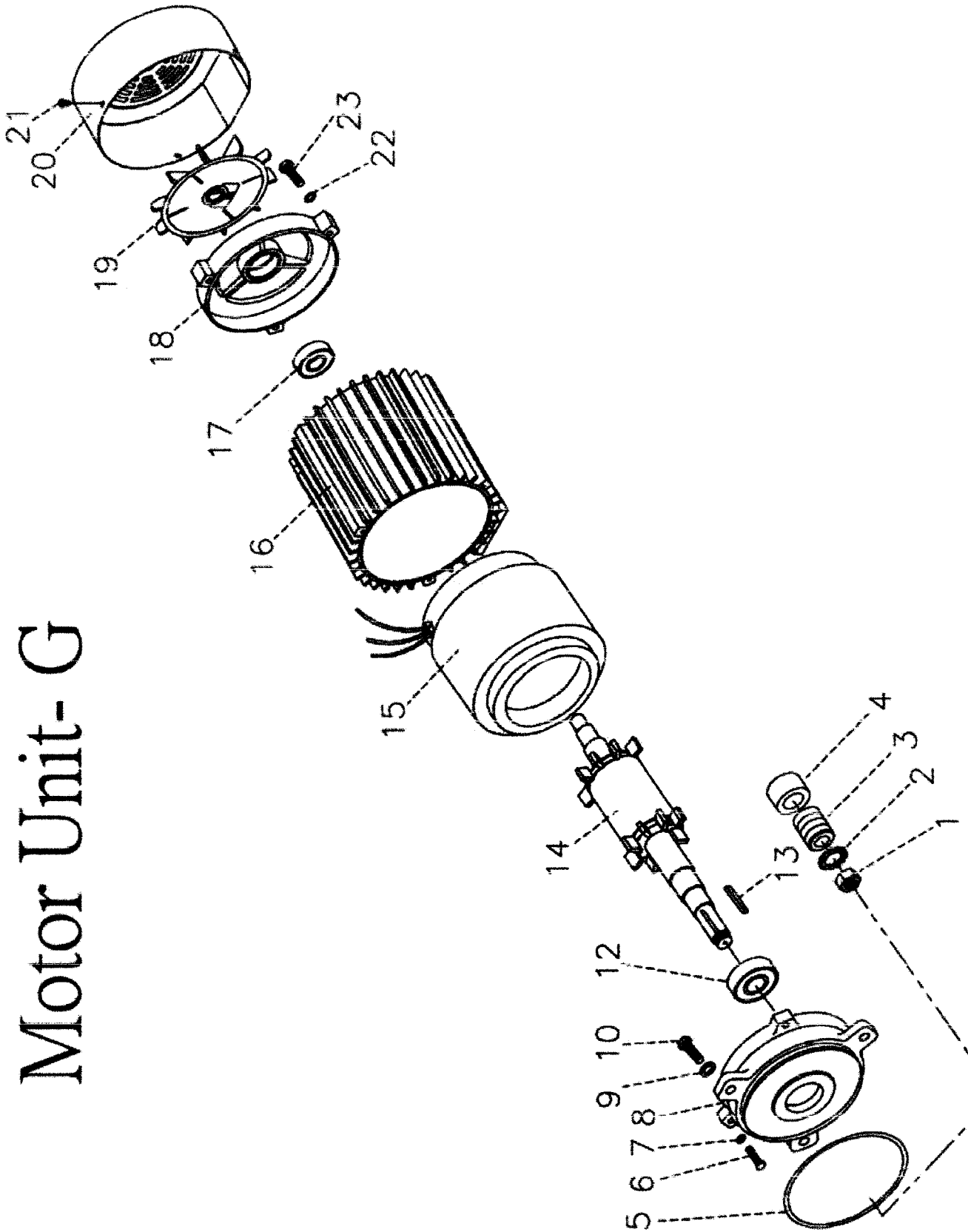

Parts Table G for Motor Unit

Item	Parts No.	Name of Parts	Qty.
1	G-8001	Nut: M25x1.25	1
2	G-8002	Washer: M25	1
3	G-8003	Worm drive: 50Hz	1
	G-8003-1	Worm drive: 60Hz	1
4	G-8004	Bronze bushing	1
5	G-8005	O-ring: P73x3	1
6	G-8006	Screw: M6x1.0	3
7	G-8007	Spring washer: M6	3
8	G-8008	Motor front cover	1
9	G-8009	Spring washer: M12	3
10	G-8010	Washer: M12x1.75	3
11	***	***	***
12	G-8012	Ball bearing: 6307zz	1
13	G-8013	Key-way: 6x45	1
14	G-8014	Motor shaft	1
15	G-8015	Motor coil: 3HP	1
16	G-8016	Motor body	1
17	G-8017	Ball bearing: 6204zz	1
18	G-8018	Motor rear cover	1
19	G-8019	Fan	1
20	G-8020	Fan cover	1
21	G-8021	Screw: M5x0.8	1
22	G-8022	Spring washer: M6	3
23	G-8023	Screw: M6x1.0	3

Control Panel Unit- J

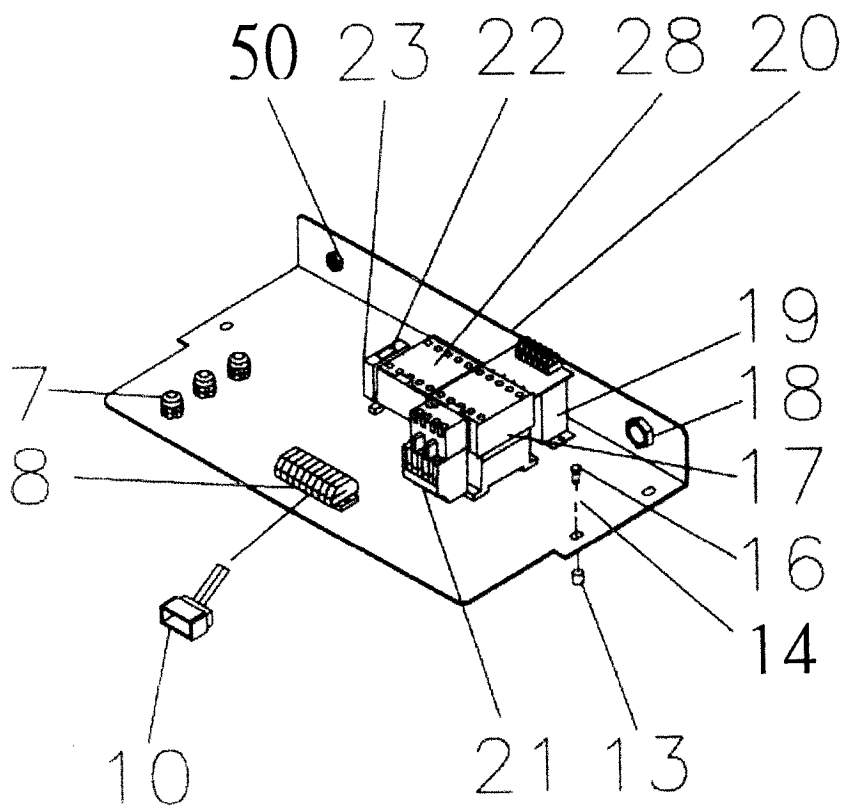
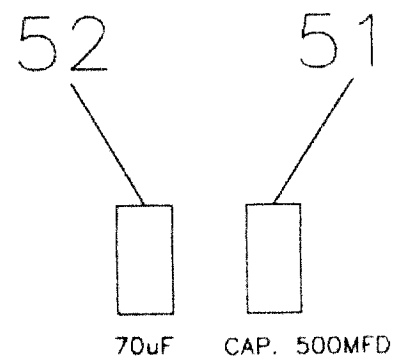
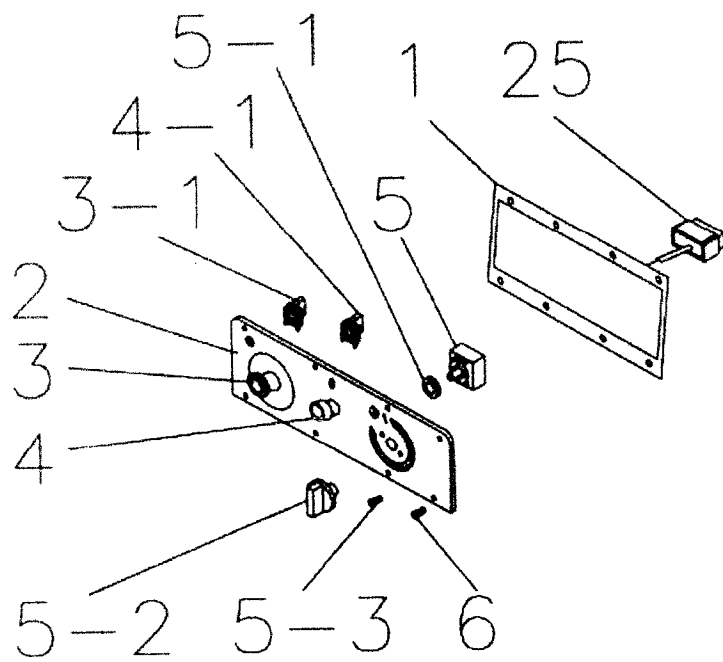

Safety Guard Unit- J

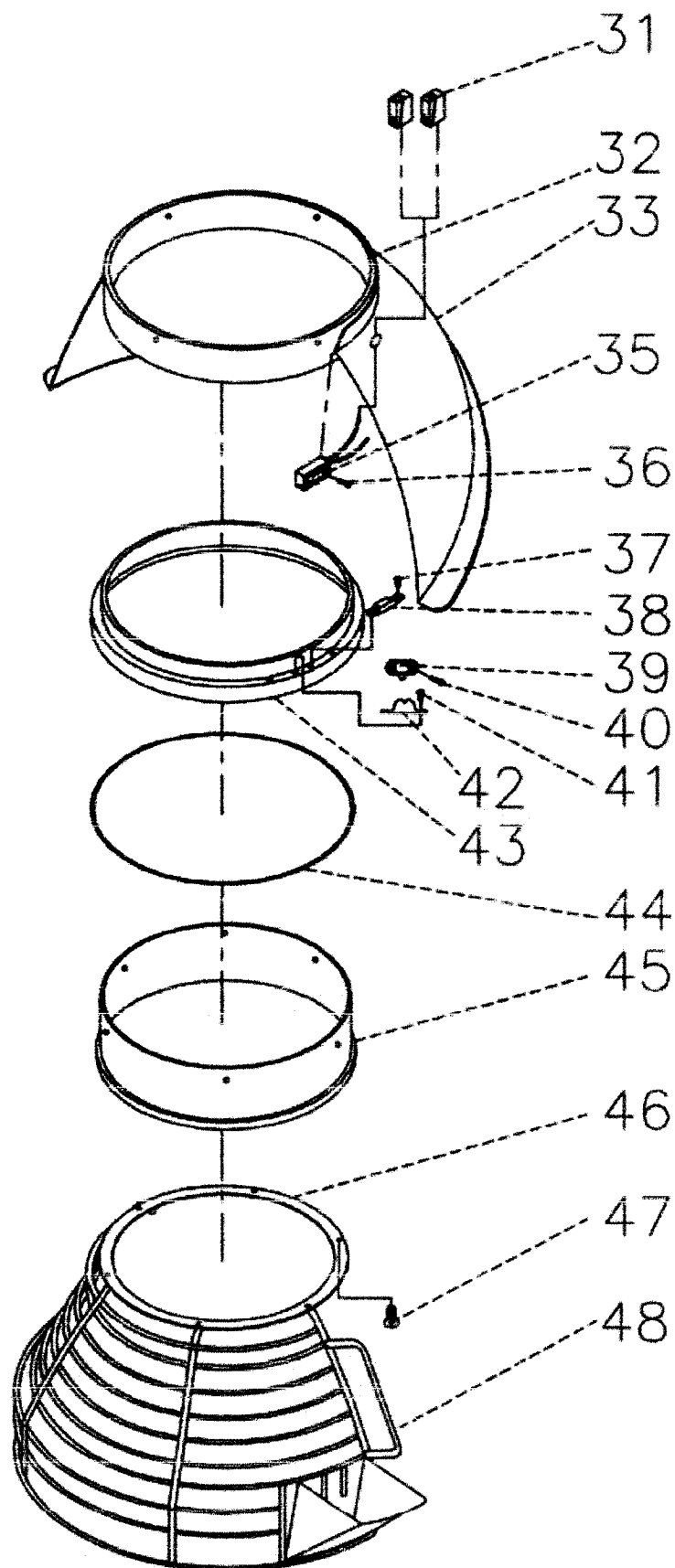

Parts Table J for Control Panel and Safety Guard Unit

Item	Parts No.	Name of Parts	Qty.
1	J-8001	Gasket	1
2	J-8002	Operation plate	1
3	J-8003	Off-stop button	1
3_1	J-8003-1	NC-switch seat	1
4	J-8004	On-start button	1
4_1	J-8004-1	No-switch seat	1
5	J-8005	Timer	1
5_1	J-8005-1	Washer	1
5_2	J-8005-2	Hand knob	1
5_3	J-8005-3	Screw: M3x0.6	2
6	J-8006	S/s screw: M4x0.7	8
7	J-8007	Support tube: F16	4
8	J-8008	Terminal block	1
9	***	***	***
10	J-8010	Connecting block	1
11	***	***	***
12	***	***	***
13	J-8013	Spacer	4
14	J-8014	Washer	4
15	***	***	***
16	J-8016	Screw: M6x1.0	4
17	J-8017	Contactora: 24V	1
18	J-8018	Support tube: F28	1
19	J-8019	Transformer: 24V	1
20	J-8020	Electronics mounting plate	1
21	J-8021	Overload relay	1
22	J-8022	Fuse	1
23	J-8023	Fuse fixture	1
24	***	***	***
25	J-8025	Connector	1
26	***	***	***
27	***	***	***
28	J-8028	Contactora: 24V	1
29	***	***	***
30	***	***	***
31	J-8031	Connector	2
32	J-8032	Internal	1
33	J-8033	Rear guard-fixed	1

Parts Table J for Control Panel and Safety Guard Unit

Item	Parts No.	Name of Parts	Qty.
34	***	***	***
35	J-8035	Microswitch	1
36	J-8036	Screw: M3x0.5	2
37	J-8037	Screw: M4x0.7	2
38	J-8038	Touch mass	1
39	J-8039	Safety guard spring lock	1
40	J-8040	Screw: M3x0.6	2
41	J-8041	Screw: M4x0.7	2
42	J-8042	Safety guard spring lock fixture	1
43	J-8043	Slide sheath	1
44	J-8044	Mat	2
45	J-8045	Planetary internal gear	1
46	J-8046	Fixed slice	1
47	J-8047	S/s screw: M5x0.8	6
48	J-8048	Safety guard	1
49	***	***	***
50	J-8050	Strain relief	1
51	J-8051	Capacitor (start)	1
52	J-8052	Capacitor (low voltage)	1

SM-B80HI Electrical Diagram Three Phase 230/400V manual bowl lift

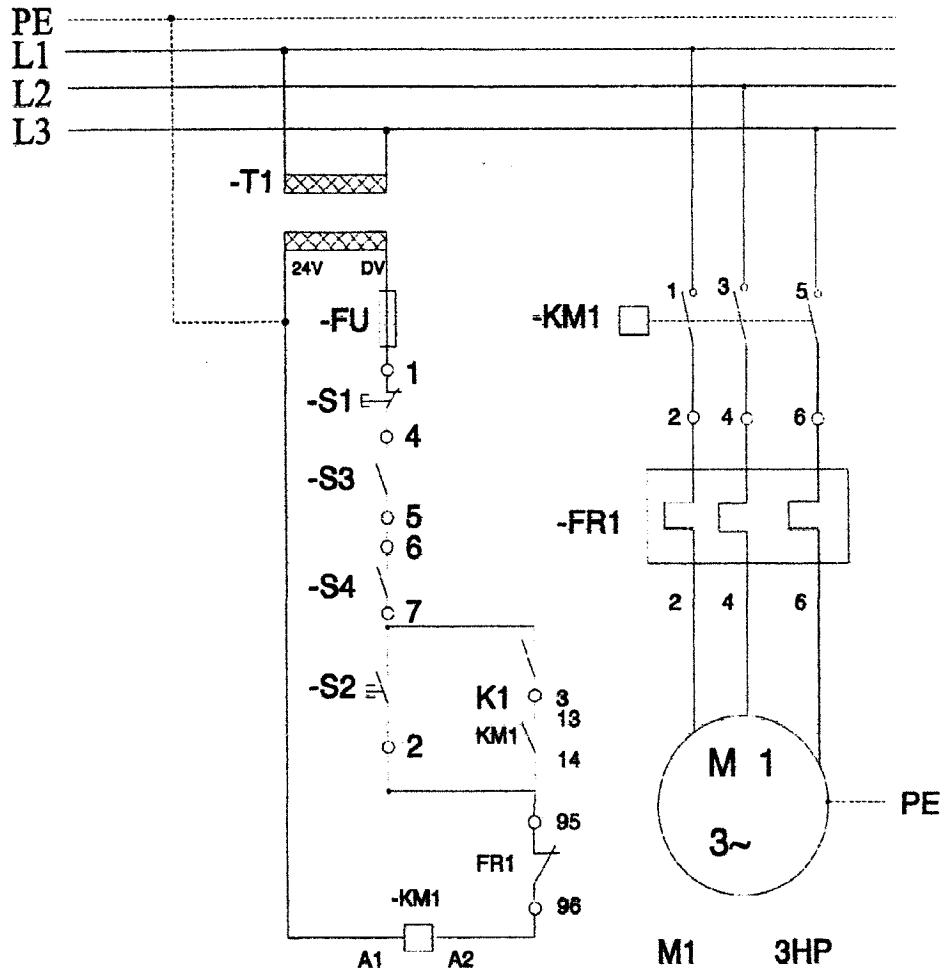

Item Description	Maker	Part number	Qty Rem.
S1 EMERGENCY STOP BUTTON	Telemecanique	XB2-BS542	1
S2 START BUTTON	Telemecanique	XB2-BW3361B	1
S3 MICROSWITCH (safty cover)	OMRON	D2VW-5-1M	1
MICROSWITCH (transmission gear)	OMRON	Z-15GW22-B	1
S4 MICROSWITCH (height adjuster)	OMRON	Z-15GQ22-B	1
KM1 CONTACTOR COIL	Allen-Brodley	100-A24NJ3	1
K1 TIMER	ANN YIH	AT-615	1
FR1 OVERLOAD RELAY	Allen-Brodley	193-A4H1	1
M1 MOTOR 3HP	SHIUH JLANN	3HP 400V	1
T1 TRANSFORMER AC24V	SUNG CHUAN	380V 24V 24VA	1
FU FUSE FIXTURE+FUSE 1A(5X20)	CONQUER	HTB-32	1

APPROVED:

DRAW:

MECH NO:

ITEM NO:

DATE:

AUG.2002

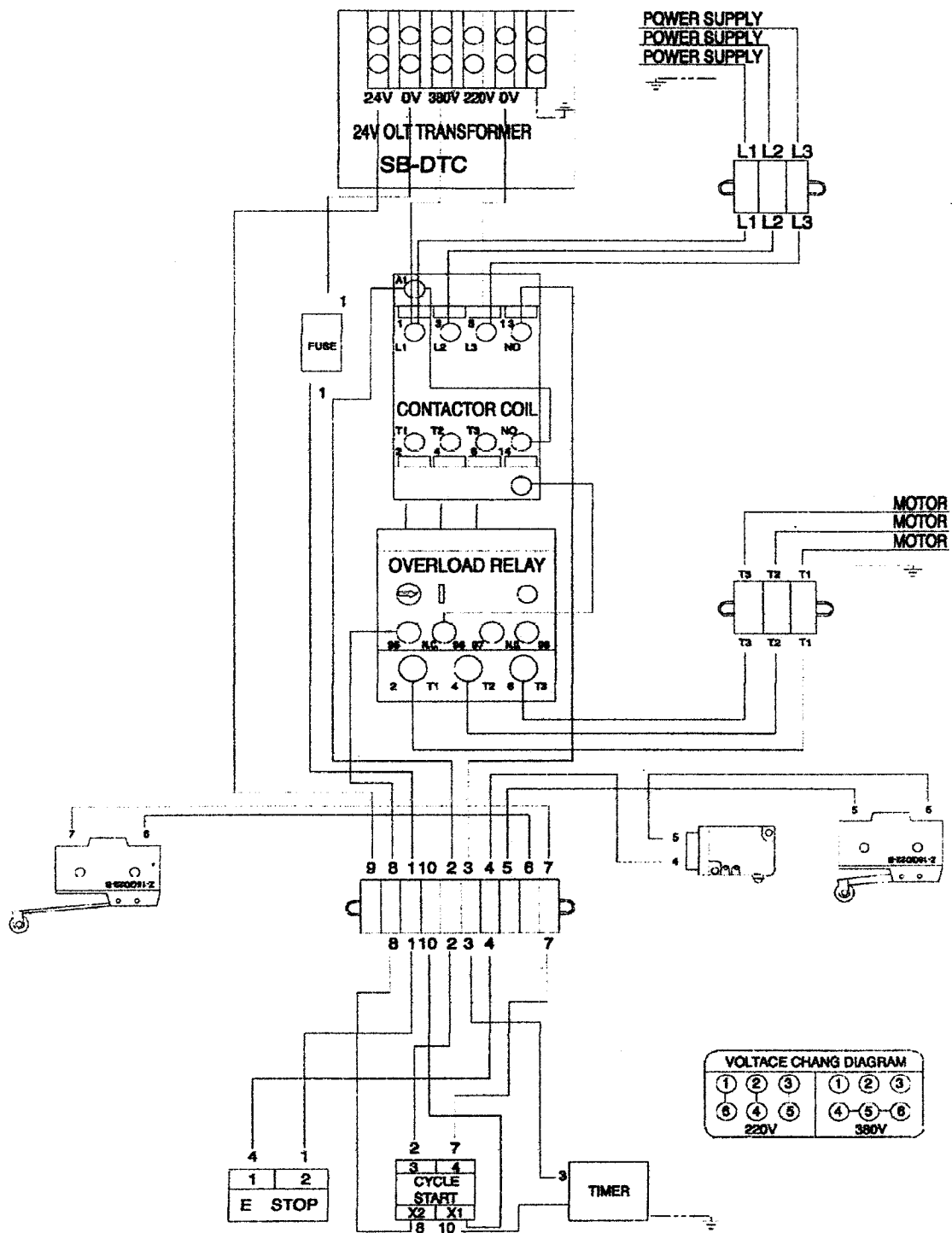

VOLTAGE CHANG DIAGRAM

①	②	③	①	②	③
④	⑤	⑥	④	⑤	⑥
220V			380V		

1 2
E STOP

2 7
3 4
CYCLE
START
X2 X1
8 10

3
TIMER